

## Bedrijfservaringen (Afval)water CCEP Dongen

Nationaal Watersymposium, Amersfoort, 8 juni 2023

Jos Peeters

Environmental Manager CCEP NL



### CCEP is **Coca-Cola's** grootste **bottelaar**



  
**€14.8mld**  
omzet<sup>1,2</sup>

  
**~33K**  
collega's

  
**29**  
landen

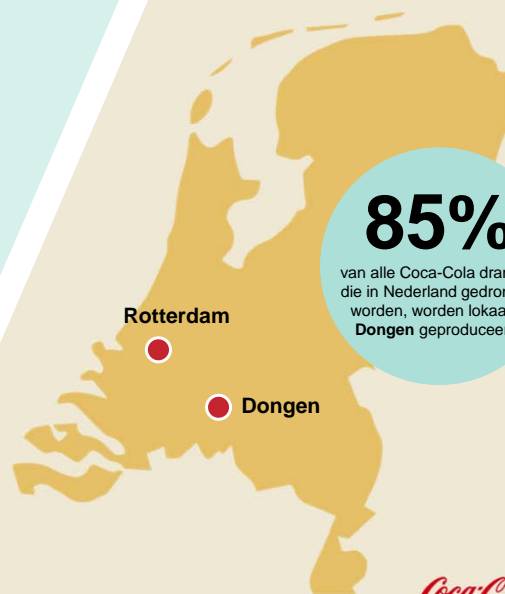

**85%**

van alle Coca-Cola dranken  
die in Nederland gedronken  
worden, worden lokaal in  
**Dongen** geproduceerd.



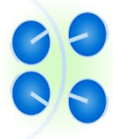

# Coca-Cola in Nederland



2 bedrijven  
merkeigenaar &  
bottelaar



800  
collega's



14  
merken



Verkocht  
op 100.000  
punten



1  
fabriek



7 miljoen  
drankjes  
per dag



# Facts & figures CCEP Dongen



2022

FTE: 492  
EVERYONE'S  
WELCOME



111 mUC BP 2022  
630 Million liters per year

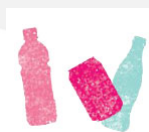

180.000 cans  
100.000 PET-bottles **100% recycled**  
48.000 Aseptic-bottles **100% recycled**  
55.000 glass bottles **Refilable**  
per hour  
2 BIB lines (package less)

Since 1957



233.000 m2



100-200 customer trucks per day  
HVO 100 fuel (90% CO2 reduction)



Vision



9 production lines



Internal Storage capacity  
> 34.600 pallets  
OE Bronze certificate



5 certified  
mineral water sources  
AWS platinum certified

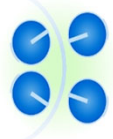

**This Is Forward**

**Onze duurzaamheidsdoelstellingen focussen zich op zes gebieden**

### Klimaat

We streven ernaar om tegen 2040 klimaatneutraal te zijn en onze uitstoot tegen 2030 met 30% te verminderen



### Verpakking

We zullen ons gebruik van verpakkingen verminderen waar we kunnen en ervoor zorgen dat het equivalent van alle verpakkingen die we gebruiken wordt ingezameld, hergebruikt of gerecycled, zodat het niet als afval of zwerfvuil eindigt.



### Dranken

We zullen consumenten een nog grotere keuze aan dranken met minder suiker bieden



### Maatschappij

We zullen een kracht ten goede zijn door inclusie en economische ontwikkeling in de samenleving te bevorderen met onze werknemers en onze gemeenschappen



### Water

We behandelen water met de zorg die het verdient in ons hele bedrijf en onze waardeketen



### Toeleveringsketen

We zullen onze hoofdingrediënten en grondstoffen duurzaam en verantwoord inkopen





**Our Headline Commitments**



Pillar	Commitment	Target
<b>CLIMATE</b>	<b>Net Zero</b>	Net zero GHG emissions (Scope 1,2 & 3) by 2040 <sup>1</sup>
	<b>GHG Emissions Reduction</b>	Reduce emissions (Scope 1,2 & 3) by 30% by 2030 <sup>2</sup>
	<b>Renewable Electricity</b>	Use 100% renewable electricity across all markets by 2030
	<b>Supplier Engagement – GHG Emissions</b>	100% of carbon strategic suppliers to set science-based targets by 2023 (Europe) & 2025 (API)
	<b>Supplier Engagement – Renewable Electricity</b>	100% of carbon strategic suppliers to use 100% renewable electricity by 2025 (Europe) & 2030 (API)
<b>PACKAGING</b>	<b>Design</b>	100% of packaging to be recyclable by 2025
	<b>Recycled Plastic</b>	50% recycled plastic in our PET bottles in Europe by 2023. Other markets by 2025
	<b>Virgin Plastic</b>	Stop using oil-based virgin plastic in our bottles by 2030
	<b>Collection</b>	Collect and recycle a bottle or a can for each one we sell by 2030
<b>WATER</b>	<b>Water Stewardship</b>	Set context-based water targets at all manufacturing sites
	<b>Replenish</b>	Replenish 100% of water we use in our beverages
	<b>Regenerative Water Use</b>	100% regenerative water use in 'leadership locations' by 2030
<b>SUPPLY CHAIN</b>	<b>Sustainable Sourcing</b>	100% of main agricultural ingredients and raw materials sourced sustainably
	<b>Human Rights</b>	100% of suppliers to be covered by our Supplier Guiding Principles – including sustainability, ethics and human rights
<b>DRINKS</b>	<b>Sugar Reduction</b>	Reduce sugar: by 10% in Europe by 2025 <sup>3</sup> by 20% in New Zealand by 2025 <sup>4</sup> by 25% in Australia by 2025 <sup>4</sup> by 35% in Indonesia by 2025 <sup>4</sup>
	<b>Low and No Calorie</b>	Over 50% of sales to come from low or no-calorie drinks by 2030 (Europe by 2025) <sup>5</sup>
<b>SOCIETY</b>	<b>Gender Diversity Management</b>	45% of management positions to be held by women by 2030
	<b>Gender Diversity</b>	A third of our workforce to be women by 2030
	<b>Disabilities</b>	10% of our workforce represented by people with disabilities by 2030
	<b>Supporting Skills Development</b>	Support the skills development of 500,000 people facing barriers in the labour market by 2030

<sup>1</sup> Europe only versus 2019. This will be updated once our work to finalise a Group-wide commitment is completed.  
<sup>2</sup> Europe only versus 2019. This will be updated once our work to finalise a Group-wide commitment is completed.  
<sup>3</sup> Europe only versus 2019. This will be updated once our work to finalise a Group-wide commitment is completed.  
<sup>4</sup> Europe only versus 2019. This will be updated once our work to finalise a Group-wide commitment is completed.  
<sup>5</sup> Europe only versus 2019. This will be updated once our work to finalise a Group-wide commitment is completed.



### Water Stewardship

- Water Usage Ratio 2022: 1,45 l/l
- Doel 2030: 1,27 l/l.

### Water Replenishment

- Hoeveelheid water welke wij onttrekken weer “teruggeven” aan de natuur.
- Doel 2030: 100%

### Regenerative Water use

- Afvalwater hernieuwbaar inzetten.
- Doel 2030: 100%



Water Stewardship

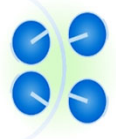

### Water Stewardship

- Waterbesparingsplan
  - Zuinig omgaan met water
  - Waterzuinige apparatuur
  - Waterscan Brabant Water:

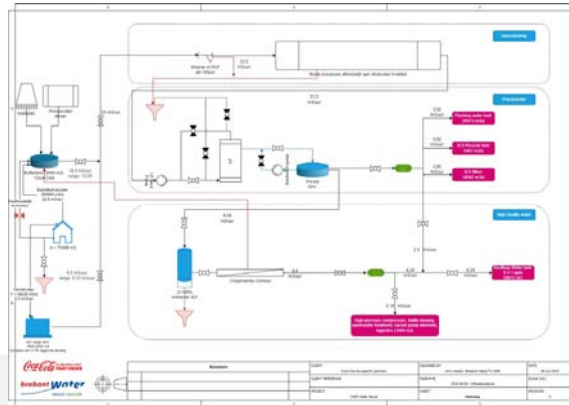

Water Replenishment

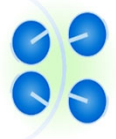

Water Replenishment



## HOE COCA-COLA WATER TERUGGEEFT AAN DE NATUUR IN NEDERLAND

Een water-replenishmentproject in samenwerking met Natuurmonumenten



**Water Replenishment Project 2021**  
**De Liskes, Bergeijk (N.Br.)**



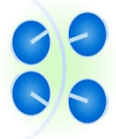

**Water Replenishment Project 2023**  
**Pastoorsweijer, Bergeijk (N.Br.)**

*Coca-Cola*  
EUROPACIFIC  
PARTNERS

*Coca-Cola*  
EUROPACIFIC  
PARTNERS

**Regenerative Wateruse**

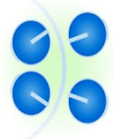

## Pilot Vossenberg Kraaiven -> Circulair Watersysteem Tilburg Noord



### Samenwerkingspartners

Tegenstrijdige belangen, gezamenlijk doel

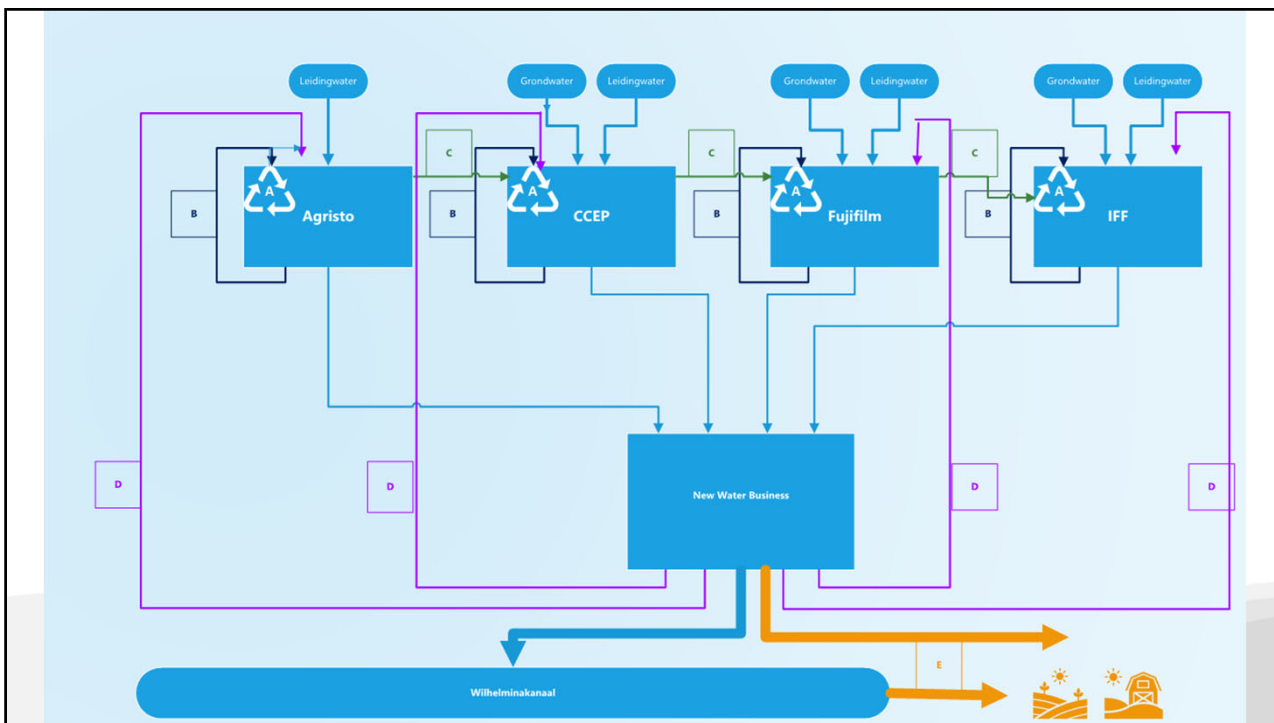
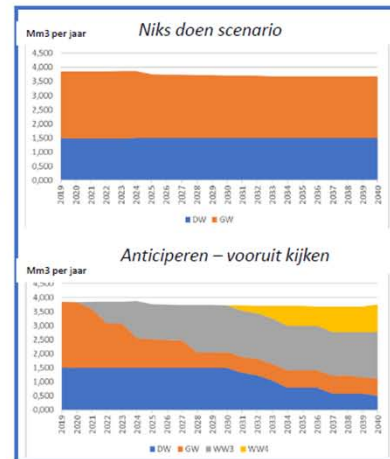



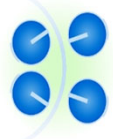

### Pilot Vossenber Kraaiven -> Circulair Watersysteem Tilburg Noord

- Fase 1: 2020 In kaart brengen van water en afvalwaterstromen
- Fase 2: 2022 Identificeren van besparingsmogelijkheden

#### INDUSTRIAL AREA KRAAIVEN – VOSSENBERG, TILBURG (NL)

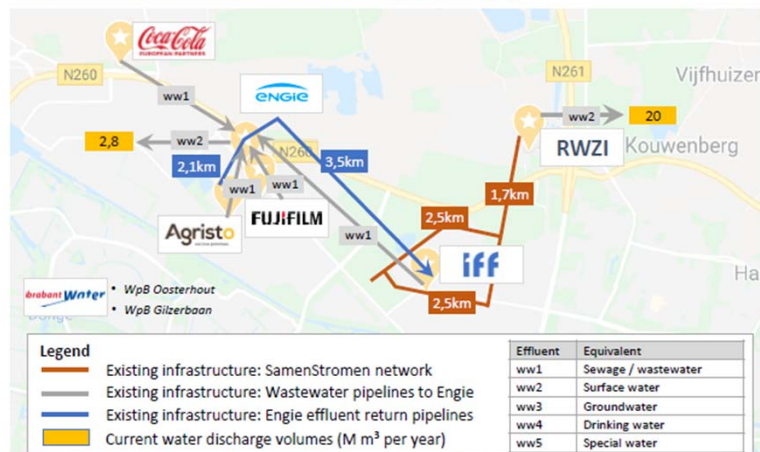

Continuing the status quo

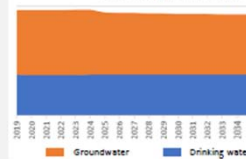

Anticipating water scarcity

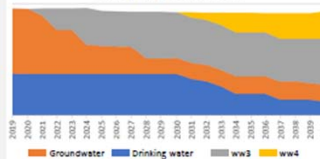

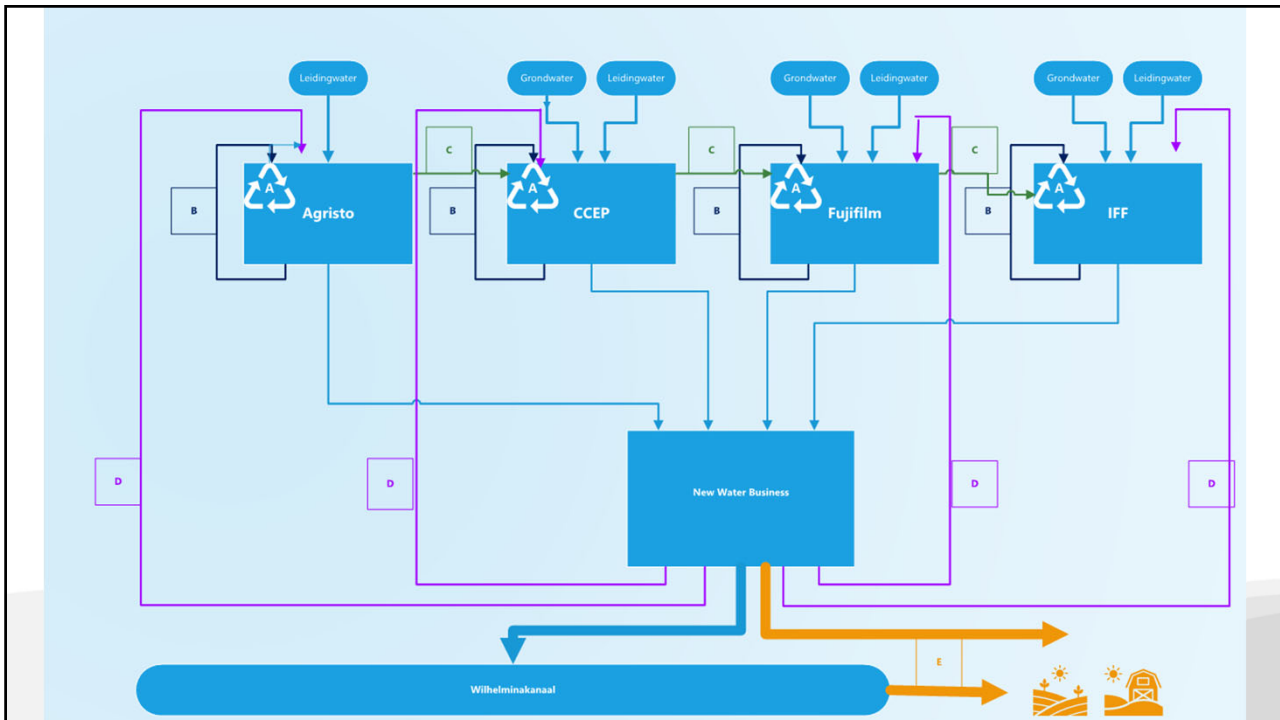
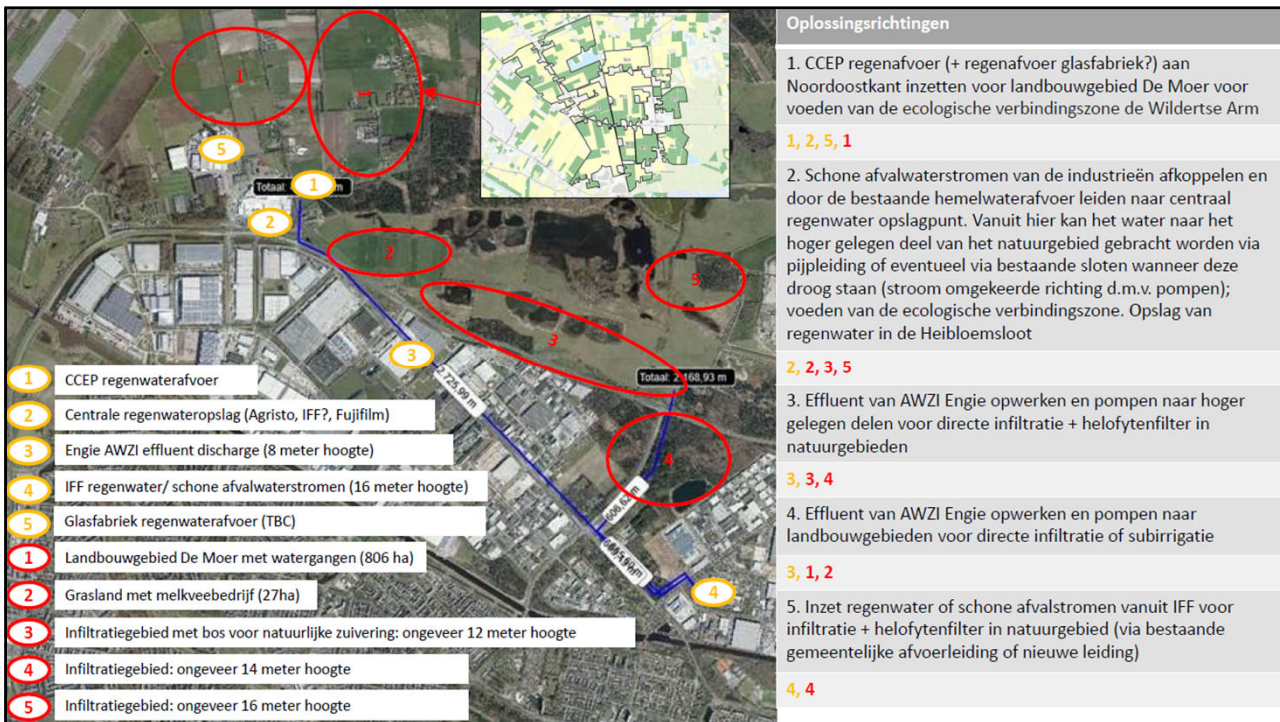
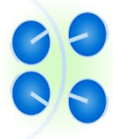

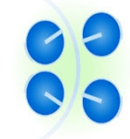

**Hick-ups:**

- **Verschil in onderwerp van besparing**
  
- **Waarom een technisch hoogstaand systeem maken, wat:**
  - **Energie verbruikt (kosten en milieu-impact)**
  - **Chemie verbruikt (kosten en milieu-impact)**
  - **Onderhoud nodig heeft (kosten en personele inzet)**
  - **Mogelijk leidt tot storingen (stilvallen processen, kosten, personele inzet)**

**Als het alternatief is:**

- **Goedkoop uit de grond onttrekken met zeer simpele bewezen techniek?**



**Huidige Status**



## Denkproces Transitie:

### Oude systeem:

Water nodig -> Leidingwater of Bronwater

Water over -> Riolering

### Nieuwe denken:

Water nodig of water over ->

Wat is de kwantiteit en kwaliteit? Waar kan dit nog ingezet worden?



## Reduce

- De duurzaamste liter water is de liter water die niet gebruikt wordt.

## Reuse

- Meerdere malen gebruiken van water, zonder behandelingsstap:
  - Bliklijnen: 3 spoelstappen met hetzelfde water
  - CIP installaties: Naspoelwater -> voorspoelwater
  - Krattenwasser met effluent van de bottlewasher

## Recycle

- Hergebruik van water met een zuiveringsproces. (toevoeging van kosten)

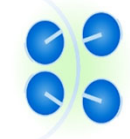

Huidige Status:



- Vraagstukken:

- Koppelen van een specifieke bron van afvalwater aan een specifiek doel van watergebruik.
  - Met of zonder waterzuivering
- Totale afvalwater zuiveren en centraal terugvoeren in het systeem?
  - Afkoppelen sanitair water?

Open

Coca-Cola  
in Nederland

Real Talk

# De waarde van water

Praat en luister mee: live of via de stream

Maandag 26 juni  
13:30 - 15:00

Meld je aan

In samenwerking met  
CHANGE INC.

[www.change.inc](http://www.change.inc) -> Evenementen